

Overview



EL-DH-604 is a wall mount door holder which adopts low power consumption that makes it more environments friendly and more durable. It will release automatically the fire door in case of fire. It also contains build-out release button for testing and build-in MOV which reverse current protection.

Specification

Product Parameter	Parameter Description
Dimensions	70L x 40W x 85H (mm)
Holding Force	50kg (110Lbs)
Voltage	12/24VDC +/- 10%
Current Draw	12V/180mA 24V/70mA
Suitable for	All kind of Single & Double Smokeproof Doors
Surface Temp	≤+20°C
Operating Temp	-10~+55°C(14-131F)
Suitable Humidity	0~90%(relative humidity)
Finishes for Shell	High Temperature Paint and Environmental Protection Zinc
Finishes for Armature	Zinc
Weight	0.9kg

Dimensions

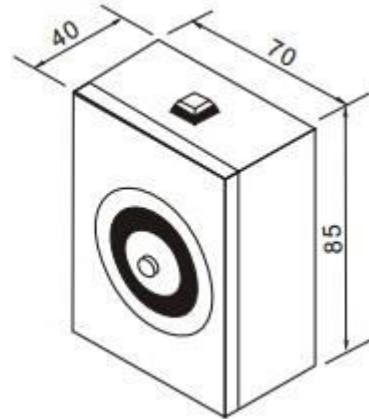
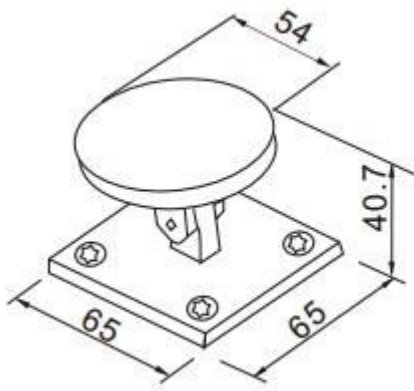

Installation

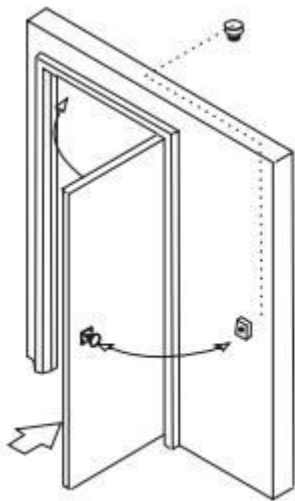

Installation

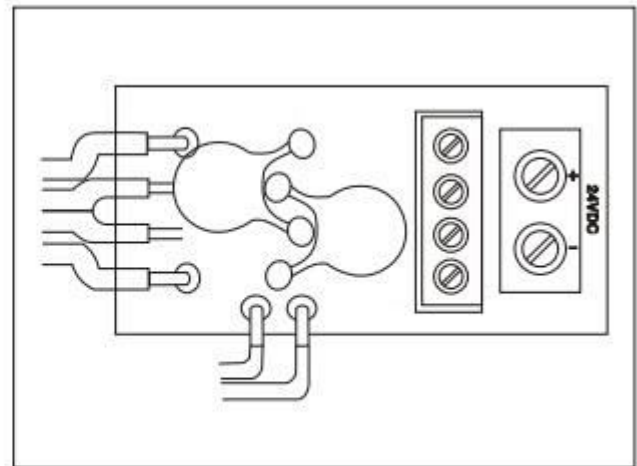

Circuit Board Instruction