



Overview

EL-DH-602 is a standard type wall mount door holder which adopts low power consumption that makes it more environments friendly and more durable. Professional anti-residual magnetism design ensures highest security. It will release automatically the fire door when fire alarm. It also contains build-out release button for testing and build-in MOV which reverse current protection.

Specification

Product Parameter	Parameter Description
Dimensions	L80 x W80 x H105 (mm)
Holding Force	50kg (110Lbs)
Voltage	12/24 VDC +/- 10% (Adjustable)
Current Draw	12V/140mA 24V/70mA
Suitable for	All kind of Single & Double Smokeproof Doors
Surface Temp	≤+20°C
Operating Temp	-10~+55°C(14-131F)
Suitable Humidity	0~90%(relative humidity)
Finishes for Shell	High Temperature Paint and Environmental Protection Zinc
Finishes for Armature	Zinc
Weight	1.0kg

Dimensions

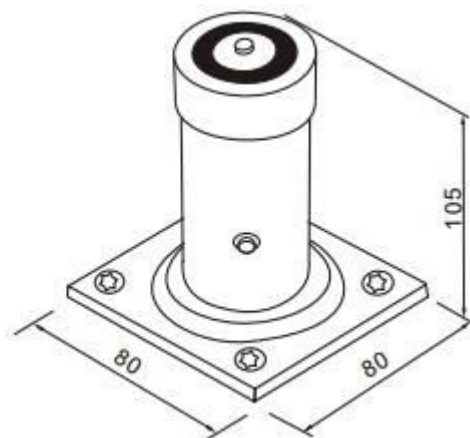
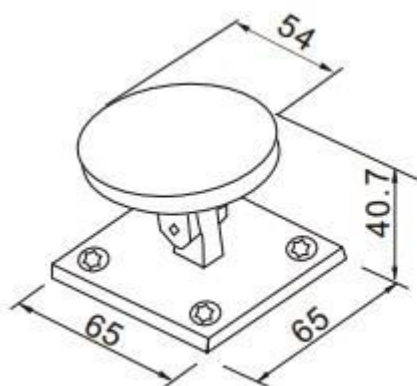

Installation

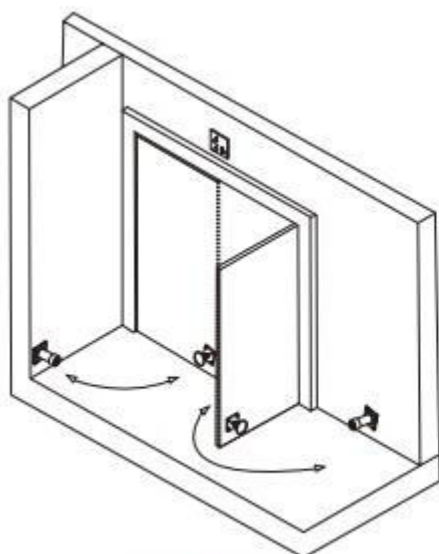

Installation

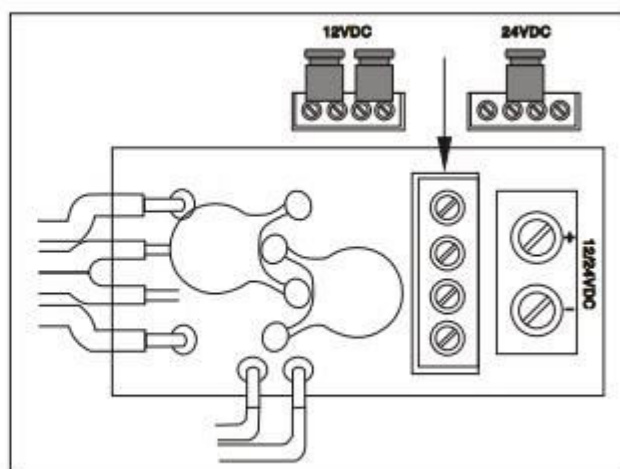

Wiring Instructions

Typical Wiring Connection from Fire Alarm Panel to Door Holder

